

COMPLETE RANGE OF
**3D ADJUSTABLE
CONCEALED
HINGES**



INVISIO
series

Edition #1 | 2024

Innovation for **total VISION™**

Ozone continues with the concept of 'Total Vision' to create transparent & elegant commercial spaces. Every fitting in our Architectural Glass Hardware range is designed to meet the concept of 'Total Vision'.

Ozone is a young, dynamic company offering Architectural Hardware & Security Solutions through a wide range of standard and customized products. A solution-centric approach has enabled Ozone to grow from a startup to one of the leading brands in the Architectural Hardware Industry. Globally, the Company has made its footprint by supplying goods to almost 40+ countries. With a Global Perspective in mind right from its inception, the Company has ensured each product has the quality and certifications so that they can be offered to all markets.

Manufacturing Capability

Our state-of-the-art Manufacturing Facilities backed by design capability enable us to provide other OEM services in India and Overseas. We can offer Stainless Steel OEM services for manufacturing of Casted, Machine Turning, & Sheet Metal Components in all grades of Stainless Steel and other metals.



AUTOMATED STATE-OF-THE-ART Manufacturing Facility

Our **manufacturing** units are equipped with the latest CNC Machines, Hi-Tech Laser Machines, Water-Jet Cutting Machines, and Automatic Polishing and Robotic Welding Machines to deliver consistent finishes. All units have unique operations that work together continuously at maximum efficiency. Each product is checked for quality and perfection, ensuring the highest level of customer satisfaction.

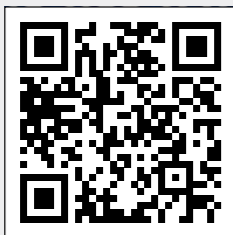

Scan QR Code for Manufacturing Facility

Cluster-1
Kala Amb,
Himachal Pradesh,
India



VMC (Vertical Machine Centre)

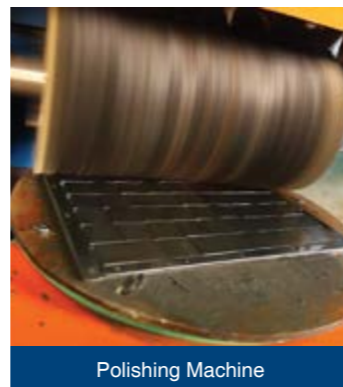

Polishing Machine



CNC Punching Machine

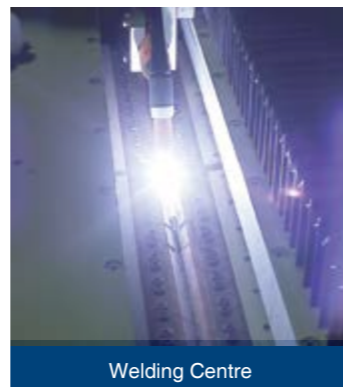

Welding Centre

Cluster-2
Ghiloth,
Rajasthan Industrial Area,
India



Our Product Range

For over two decades, Ozone has offered Architectural Hardware Solutions with a diversified portfolio of more than 5000 products. These products are tested and certified internationally for quality, functionality, and performance.

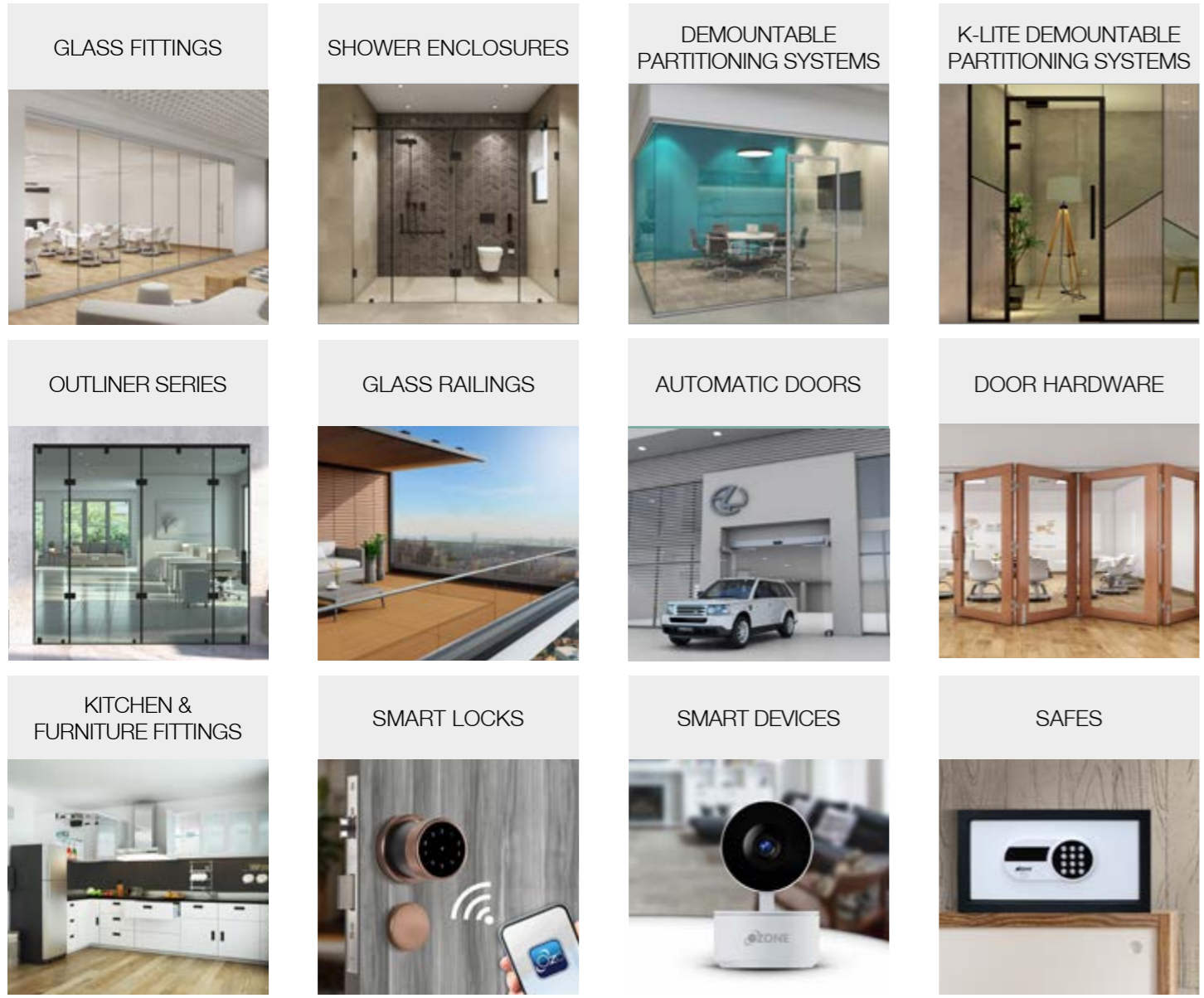

CONTENT

OZ-3D-INVH-40 STD	01-02
OZ-3D-INVH-60 STD	03-04
OZ-3D-INVH-80 STD	05-06
OZ-3D-INVH-100 STD	07-08
OZ-3D-INVH-120 STD	09-10
OZ-3D-INVH-200 STD	11-12

Ozone has partnered with **KUBIK** to create India's most extensive range of Complete Partitioning Solutions for Homes, Offices, Banquets, Schools, and similar establishments. The new entity is named KUBOZ Arc Private Limited.



A COMPLETE RANGE OF 3D ADJUSTABLE CONCEALED HINGES

OZONE INVISIO CONCEALED HINGE

The **OZONE 3D ADJUSTABLE CONCEALED HINGES** offer unmatched reliability, aesthetics, and versatility. These hinges let you achieve minimalism in your door design while enjoying superior functionality.

Common door problems such as sagging, foundation wall settling, or warpage caused by changes in temperature and moisture often require door assembly adjustments to maintain functionality. However, it allows you to adjust the door in three dimensions (Horizontal, Vertical & In/Out) using a simple Allen wrench without needing to remove or resize the door.

The **OZONE 3D ADJUSTABLE CONCEALED HINGES** have a minimalist and refined appearance, superior functionality, maintenance-free operation, and the capability to handle doors weighing upto 321Kgs make it the perfect choice for swing doors.

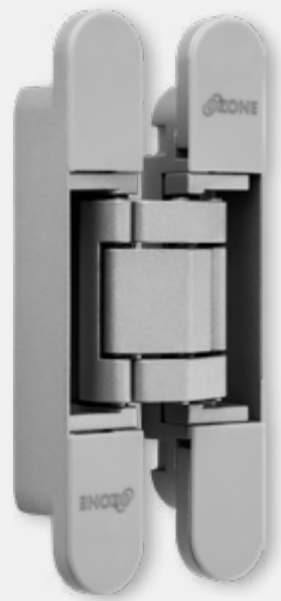

OZ-3D-INVH-40 STD

Load Capacity
Upto 40kg



OZ-3D-INVH-60 STD

Load Capacity
Upto 60kg

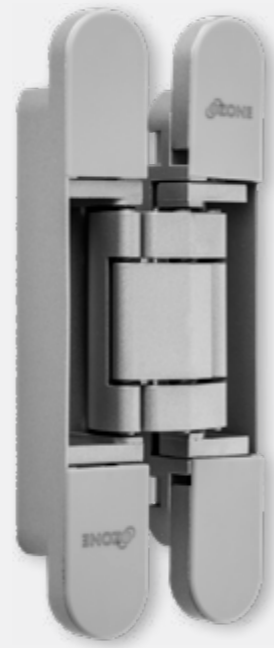

OZ-3D-INVH-80 STD

Load Capacity
Upto 80kg



OZ-3D-INVH-100 STD

Load Capacity
Upto 100kg

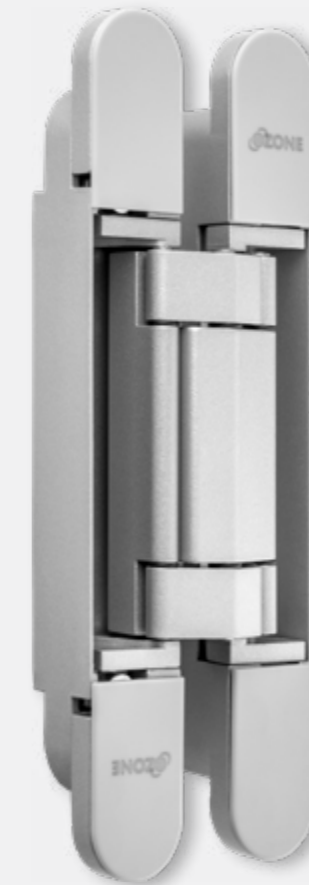

OZ-3D-INVH-120 STD

Load Capacity
Upto 120kg



OZ-3D-INVH-200 STD

Load Capacity
Upto 200kg



OZ-3D-INVH-40 STD

Upto 40kg

Load Capacity

The table outlines the suggested door weight based on the number of hinges and door width at the minimum door height of 2000mm, considering the correct adjustment with all hinges carrying the load.

No. of Hinges	Door Width "W"			
	700mm	800mm	900mm	1000mm
	Weight (Kg)			
2	51kg	45kg	40kg	36kg
3	57kg	51kg	45kg	41kg
4	64kg	56kg	50kg	45kg

OZ-3D-INVH-40 STD

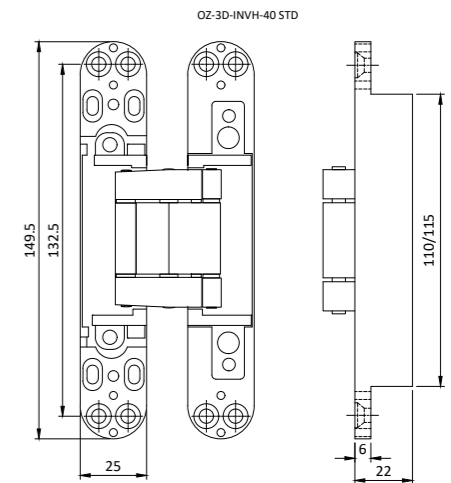
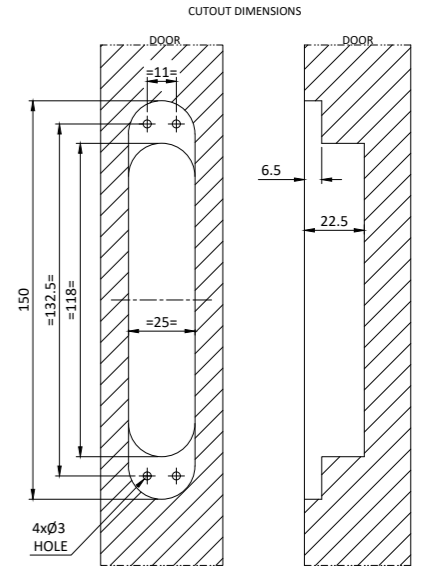

Product Features:

- Completely invisible hinge
- 3D adjustable (vertical ± 3 mm, horizontal ± 2 mm, depth ± 1 mm)
- Composite slide bearings do not require lubrication
- Applicable for both right and left doors

Technical Details:

Load Capacity	40kg (2 Nos.)
Maximum Door Width	900mm
Minimum Door Thickness	40mm
Door Side	150mm (H) 25mm (W) 22.5mm (D)
Frame Side	150mm (H) 25mm (W) 22.5mm (D)
Cutting Diameter	25mm
Opening Angle	180°
Fixing Screw	Ø5mm

Available Finishes:



SSS Matt

Antique Brass

Gold



OZ-3D-INVH-60 STD

Upto 60kg

Load Capacity

The table outlines the suggested door weight based on the number of hinges and door width at the minimum door height of 2000mm, considering the correct adjustment with all hinges carrying the load.

No. of Hinges	Door Width "W"			
	700mm	800mm	900mm	1000mm
	Weight (Kg)			
2	77kg	68kg	60kg	54kg
3	87kg	77kg	68kg	61kg
4	96kg	85kg	75kg	68kg

OZ-3D-INVH-60 STD

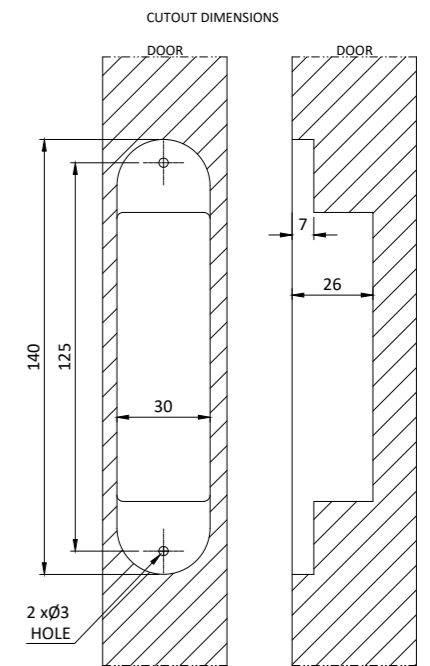
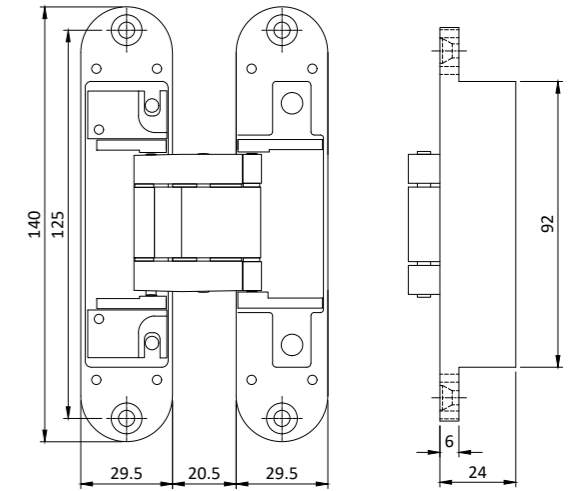

Product Features:

- Completely invisible hinge
- 3D adjustable (vertical ± 2.5 mm, horizontal ± 1.0 mm, depth ± 1.5 mm)
- Composite slide bearings do not require lubrication
- Applicable for both right and left doors

Technical Details:

Load Capacity	60kg (2 Nos.)
Maximum Door Width	900mm
Minimum Door Thickness	40mm
Maximum Door Height	2286mm
Door Side	140mm (H) 29.5mm (W) 25mm (D)
Frame Side	140mm (H) 29.5mm (W) 25mm (D)
Opening Angle	180°
Fixing Screw	$\varnothing 5 \times 40$ mm

Available Finishes:





OZ-3D-INVH-80 STD

Upto 80kg

Load Capacity

The table outlines the suggested door weight based on the number of hinges and door width at the minimum door height of 2000mm, considering the correct adjustment with all hinges carrying the load.

No. of Hinges	Door Width "W"			
	700mm	800mm	900mm	1000mm
	Weight (Kg)			
2	103kg	90kg	80kg	72kg
3	115kg	100kg	90kg	81kg
4	129kg	113kg	100kg	90kg

OZ-3D-INVH-80 STD

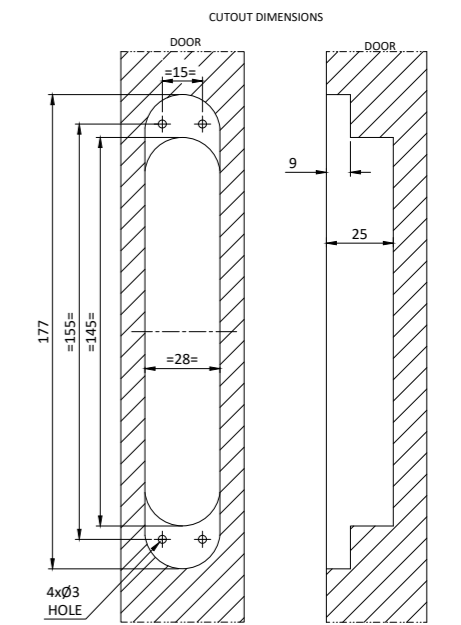
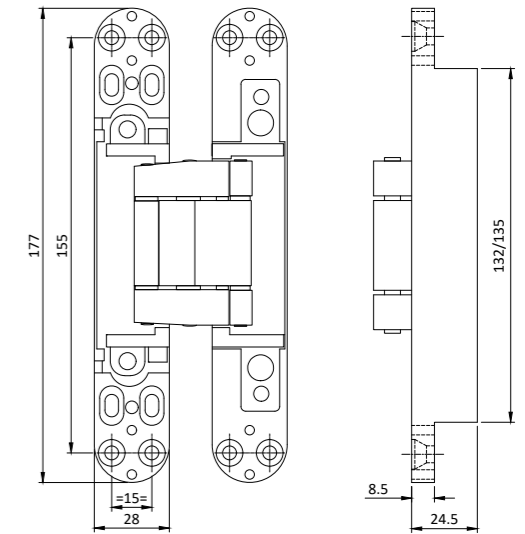

Product Features:

- Completely invisible hinge
- Suitable for unrebated and flush rebated doors
- 3D adjustable (vertical ± 3 mm, horizontal ± 3 mm, depth ± 1 mm)
- Composite slide bearings do not require lubrication
- Can be installed on both right and left opening doors

Technical Details:

Load Capacity	80kg (2 Nos.)
Maximum Door Width	900mm
Minimum Door Thickness	40mm
Door Side	177mm (H) 28mm (W) 25mm (D)
Frame Side	177mm (H) 28mm (W) 25mm (D)
Opening Angle	180°
Fixing Screw	$\varnothing 5$ mm

Available Finishes:

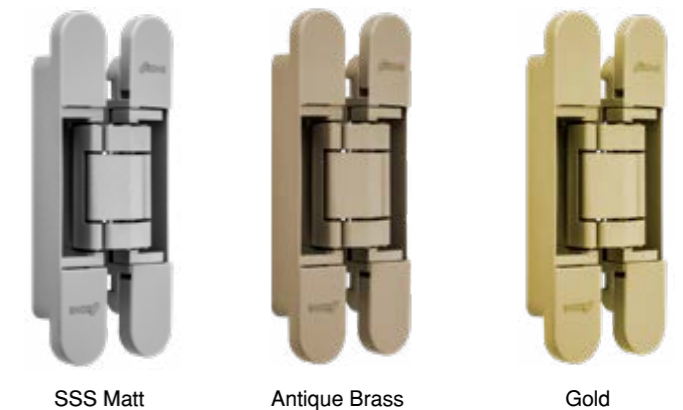



OZ-3D-INVH-100 STD

Upto 100kg

Load Capacity

The table outlines the suggested door weight based on the number of hinges and door width at the minimum door height of 2000mm, considering the correct adjustment with all hinges carrying the load.

No. of Hinges	Door Width "W"			
	700mm	800mm	900mm	1000mm
	Weight (Kg)			
2	129kg	113kg	100kg	90kg
3	145kg	127kg	112kg	101kg
4	161kg	141kg	125kg	113kg

OZ-3D-INVH-100 STD

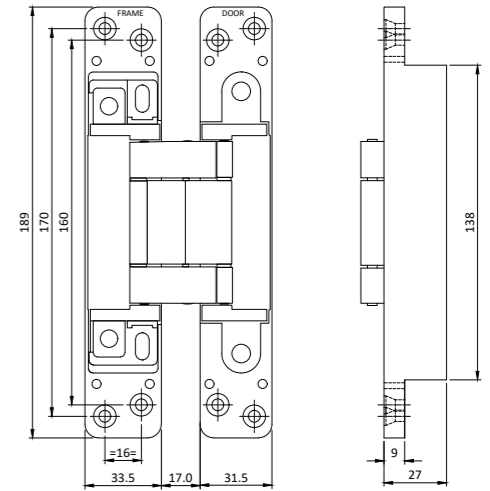

CUTOUT DIMENSIONS

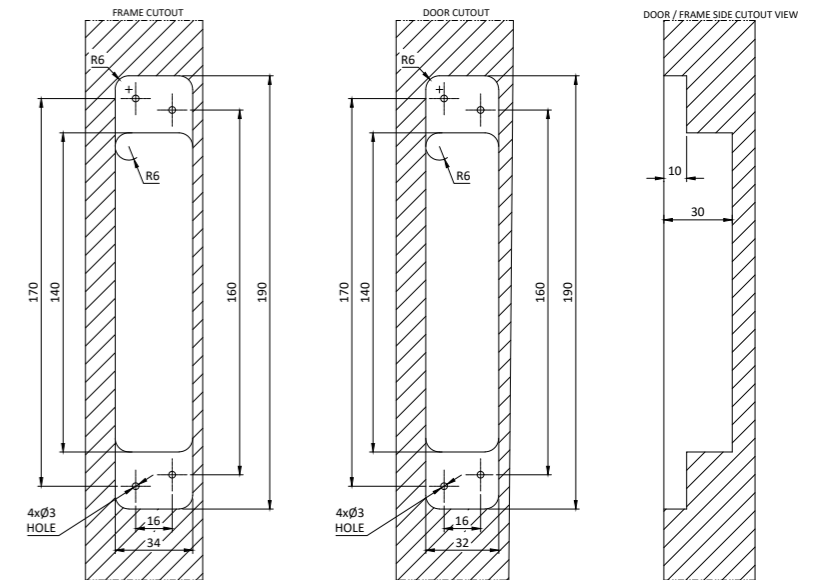

Product Features:

- Completely invisible hinge
- 3D adjustable (vertical ± 3 mm, horizontal ± 1.0 mm, depth ± 1.5 mm)
- Composite slide bearings do not require lubrication
- Right and left doors applicable

Technical Details:

Load Capacity	100kg (2 Nos.)
Maximum Door Width	940mm
Minimum Door Thickness	40mm
Door Side	189.8mm (H) 31.8mm (W) 28mm (D)
Frame Side	189.8mm (H) 33.8mm (W) 28mm (D)
Opening Angle	180°
Fixing Screw	Ø5X40mm

Available Finishes:

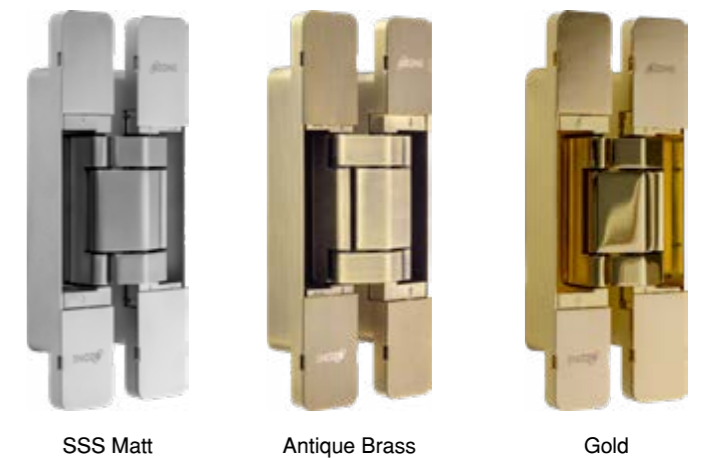

SSS Matt

Antique Brass

Gold



OZ-3D-INVH-120 STD

Upto 120kg

OZ-3D-INVH-120 STD

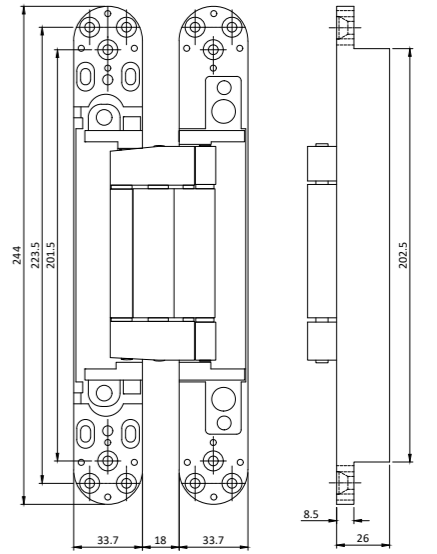

CUTOUT DIMENSIONS

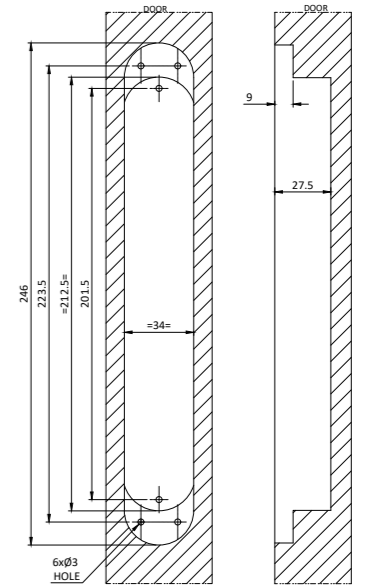

Product Features:

- Completely invisible hinge
- 3D adjustable (vertical ± 2 mm, horizontal ± 1.5 mm, depth ± 3 mm)
- Composite slide bearings do not require lubrication
- Applicable right and left doors

Technical Details:

Load Capacity	120kg (2 Nos.)
Maximum Door Width	940mm
Minimum Door Thickness	40mm
Door Side	246mm (H) 26.5mm (W) 34mm (D)
Frame Side	246mm (H) 26.5mm (W) 34mm (D)
Opening Angle	180°
Fixing Screw	Ø5mm

Available Finishes:



SSS Matt

Antique Brass

Gold



OZ-3D-INVH-200F STD

Upto 200kg

Load Capacity

The table outlines the suggested door weight based on the number of hinges and door width at the minimum door height of 2000mm, considering the correct adjustment with all hinges carrying the load.

No. of Hinges	Door Width "W"			
	700mm	800mm	900mm	1000mm
	Weight (Kg)			
2	257kg	225kg	200kg	180kg
3	289kg	253kg	225kg	203kg
4	321kg	281kg	250kg	225kg

OZ-3D-INVH-200 STD

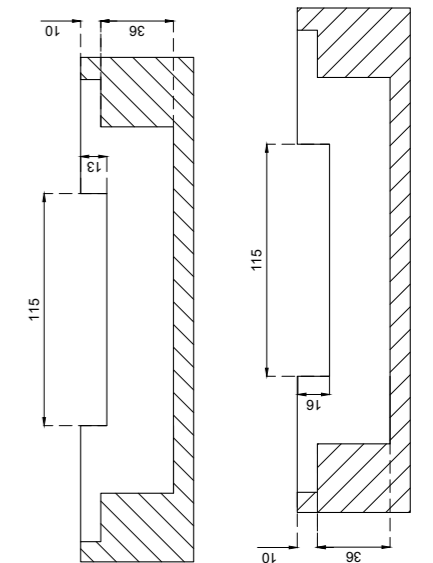
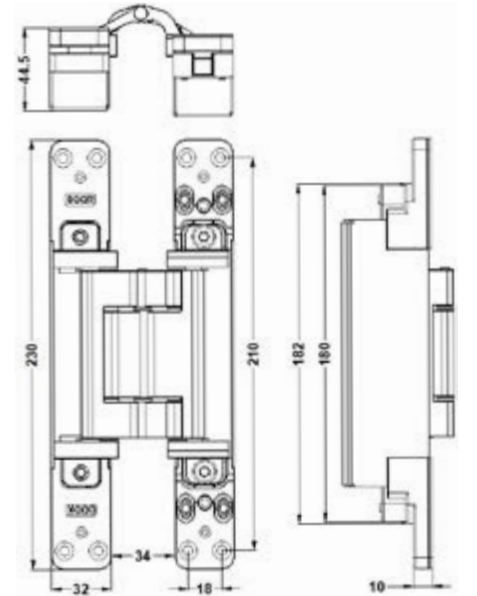

Product Features:

- Completely invisible hinge
- 3D adjustable (vertical ± 3 mm, horizontal ± 2 mm, depth ± 2 mm)
- Composite slide bearings do not require lubrication
- Applicable for right and left doors

Technical Details:

Load Capacity	200kg (2 Nos.)
Maximum Door Width	940mm
Minimum Door Thickness	50mm
Maximum Door Height	2286mm
Door Side	230mm (H) 32mm (W) 44.5mm (D)
Frame Side	230mm (H) 32mm (W) 44.5mm (D)
Opening Angle	180°

Available Finishes:

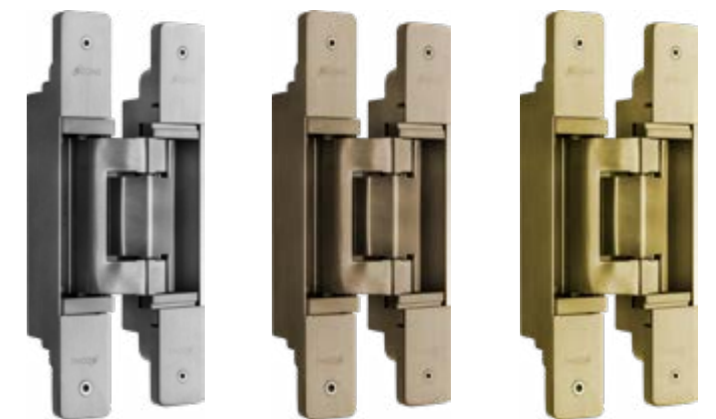

SSS Matt

Antique Brass

Gold

3D Invisio Hinge Components

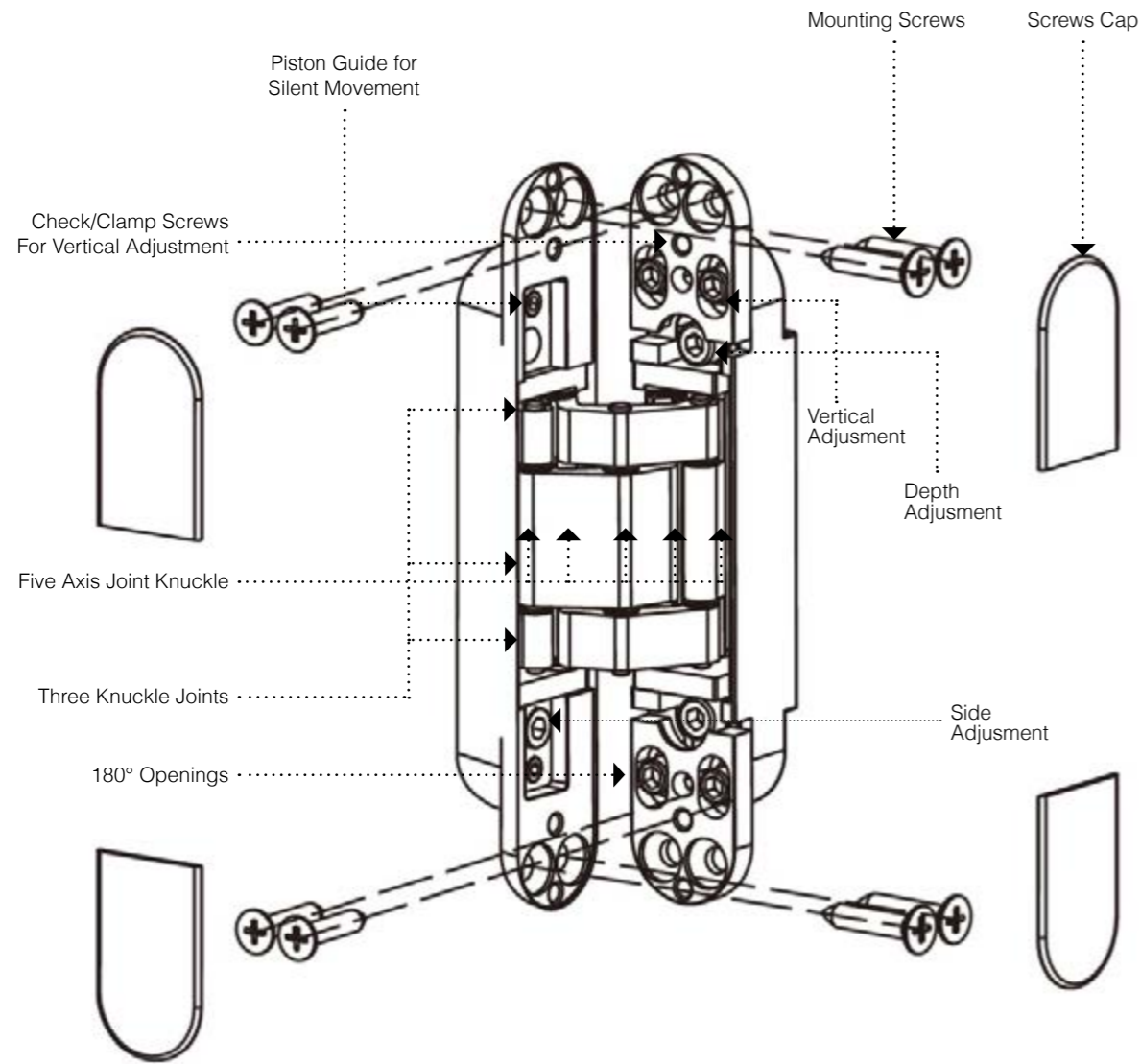

3D Invisio Hinge at a Glance

Lubrifications:

- Ozone Invisio Hinges are maintenance-free and do not need periodic lubrication.
- The Hinges use revolutionary self-lubricated anti-wear material.
- The design of the joints helps reduce friction and hence increases the life of the product.

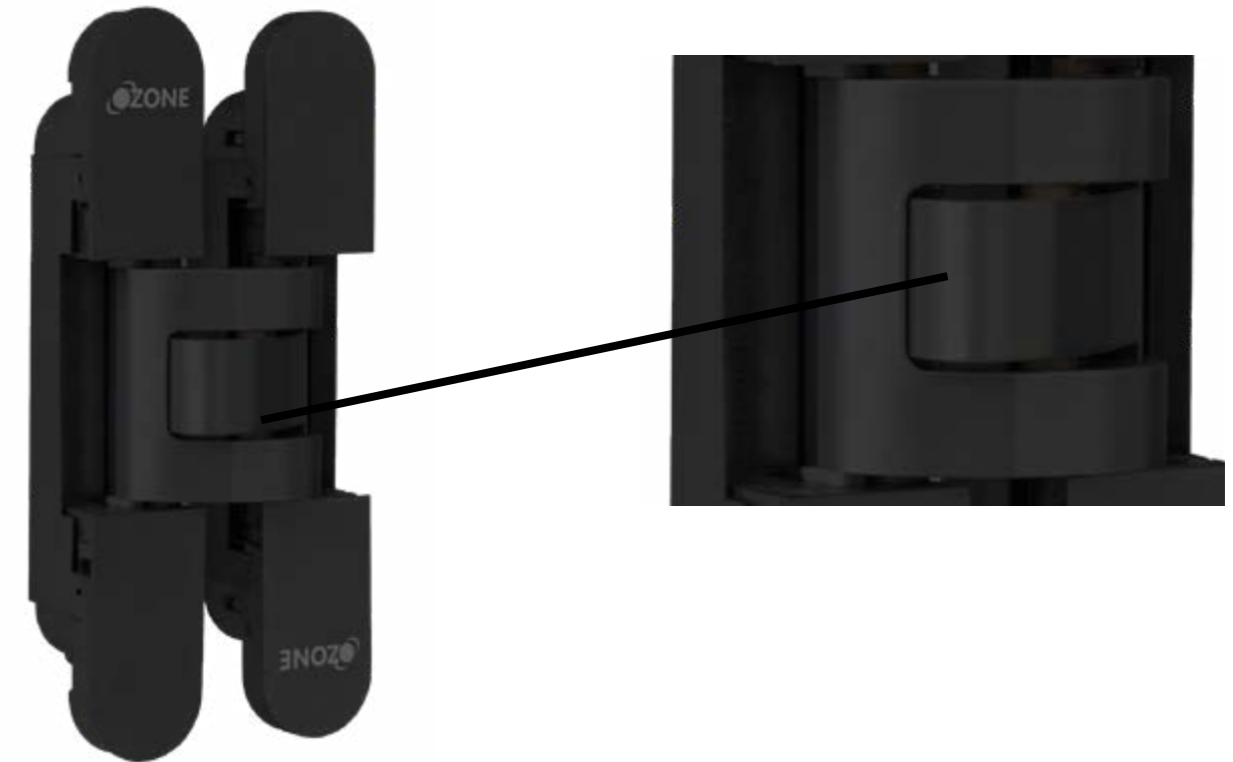

Precautions:

- Avoid lubricating the hinge or using any solvent/oil spray.
- Clean visible parts of the hinge using a clean and dry cloth.
- Refrain painting the hinge, as paint may block and jam the hinge mechanism.
- Do not use any solvents/chemicals/surfactants/abrasives to clean the hinges.

General Check:

- Check if the door frame is squared.
- Verify the perimeter of both the frame and door leaf.
- Insure the hinge is securely fixed.
- Confirm if the vertical and depth adjustments are securely locked.
- Check the gaskets / locks and other accessories used.

Arrangement of Hinges

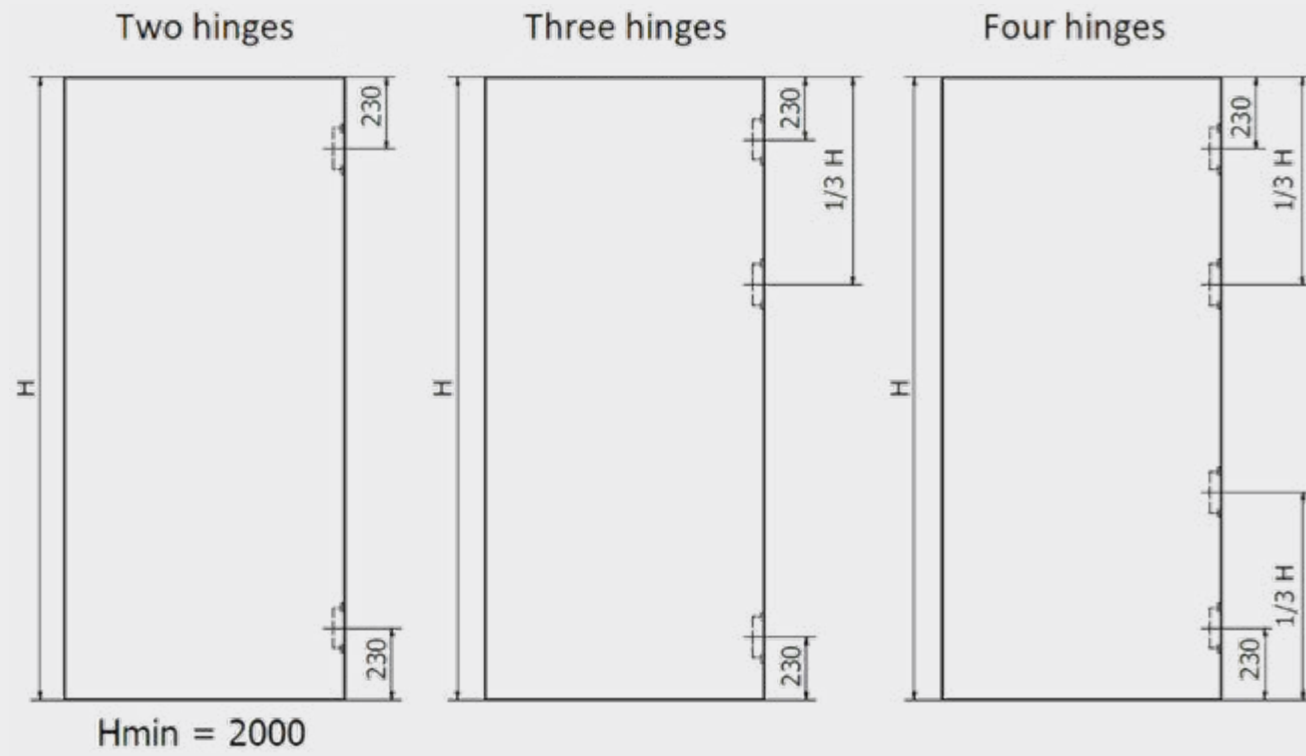

ITEM DESCRIPTION		
CAPACITY	FINISH	ITEM CODE
40kg	Silver	OZ-3D-INVH-40 STD AN
	Antique Brass	OZ-3D-INVH-40 STD AB
	Gold	OZ-3D-INVH-40 STD GOLD
	Black Matt	OZ-3D-INVH-40 STD BM
60kg	Silver	OZ-3D-INVH-60 STD AN
	Antique Brass	OZ-3D-INVH-60 STD AB
	Gold	OZ-3D-INVH-60 STD GOLD
	Black Matt	OZ-3D-INVH-60 STD BM
80kg	Silver	OZ-3D-INVH-80 STD AN
	Antique Brass	OZ-3D-INVH-80 STD AB
	Gold	OZ-3D-INVH-80 STD GOLD
	Black Matt	OZ-3D-INVH-80 STD BM
100kg	Silver	OZ-3D-INVH-100 STD AN
	Antique Brass	OZ-3D-INVH-100 STD AB
	Gold	OZ-3D-INVH-100 STD GOLD
	Black Matt	OZ-3D-INVH-100 STD BM
120kg	Silver	OZ-3D-INVH-120 STD AN
	Antique Brass	OZ-3D-INVH-120 STD AB
	Gold	OZ-3D-INVH-120 STD GOLD
	Black Matt	OZ-3D-INVH-120 STD BM
200kg	Silver	OZ-3D-INVH-200 STD AN
	Antique Brass	OZ-3D-INVH-200 STD AB
	Gold	OZ-3D-INVH-200 STD GOLD
	Black Matt	OZ-3D-INVH-200 STD BM

International Offices



Melbourne, Australia

32-40 Tarnard Drive, Braeside VIC
3195, Tel: +61 1300 088 225
Mob +61 (0) 4 301 301 02
info@ozoneaustralia.com.au
www.ozoneaustralia.com.au



Dubai, UAE

OZONE MEA TRADING LLC
Office no 129, Al Uruba Business
center, garhoud views building,
mezzanine floor (M1-3) Al
Garhoud, PO Box 430704,
Dubai UAE.

Works

Cluster-1

Ozone Overseas Pvt. Ltd.
Trilokpur Road, Kheri,
Nahan District-Sirmour,
Kala Amb,
Himachal Pradesh

Cluster-2

Ozone Overseas Pvt. Ltd.
Industrial Area Ghiloth,
Alwar,
Rajasthan

For Security Solutions:

Gurugram*

#548 Udyog Vihar, Phase 5,
Sector 19, Gurugram,
Haryana-122016
Tel: +91-124-4961164, 65

Ozone Experience Centre

Build HQ, Raja Annamalai Building,
1st Floor, Rukmani Lakshmipathi Rd,
Egmore, Chennai,
Tamil Nadu - 600008

Ozone Experience Centre

Mehrauli-Gurgaon Road,
Opp. Metro Pillar No-94,
Gadaipur, Sector-28,
New Delhi-110030

Branch Offices

Ahmedabad

407, 4th Floor, Shivalik Abaise,
Opp. Shell Petrol Pump,
Prahaldnagar,
Ahmedabad - 380051
Tel: +91-079-29706789

Bengaluru*

No. 424, 2nd Floor, Above
HDFC Bank,
Passport Office Road, 6th block,
Koramangala, Bangalore - 560034
Tel: +91-80-41207539
blrhub@ozone-india.com

Chandigarh

SCO 907, NAC Mani Majra
Near Solitaire Hotel,
Chandigarh - 160101
Mob: +91-9316001154

Chennai*

1-A, Jasoda Apartments,
No: 12, Ground Floor, Bank Street,
Kilpauk, Chennai - 600010.
Tel: 044-43802063

Cochin

No. 737/11, Opp. Lotus Club,
Warriam Road, Ernakulam, Cochin
Kerala - 682016
Mob: +91-7291981739

Hyderabad

Unit # 704, 7th Floor,
Shangrila Plaza,
Road No. 2, Banjara Hills,
Hyderabad - 500034

Indore

503, B Block,
Prakrati Corporate,
Y N Road, Indore - 452001
Mob: +91-9589589902

Jaipur

27, 5th Floor, Mahima Trinity Mall,
Swey Farm, New Sanganer Road,
Jaipur-302019
Tel: +91-141-2294261
jaipurhub@ozone-india.com

Kolkata

4 Govt Place, 4th floor,
Room No:- 4H
Delta House. Kolkatta - 700001
Mob: +91-9831176481

Lucknow*

Ground Floor,
Eldeco Corporate Chambers,
Vibhuti Khand, Gomti Nagar,
Lucknow - 226010
Tel: +91-0522-4109647
Mob: 9794970000

Mumbai

The Avenue, 607,
Near Waterstones Hotel,
Int. Airport Road,
Marol, Andheri (E),
Mumbai - 400059
Tel : +91-22-28306453
Mob: +91-7045775977

Pune

#105, 1st Floor, Suyog Center
Market Yard, Gultekdi,
Pune - 411037
Mob: +91-7678117567

Surat

201, Luxuria Business Hub,
Nr.V.R.Mall, Surat-Dumas Road,
New Magdalla Road,
Surat - 395007
Mob: +91-9724009921

Visakhapatnam

Door No 48-3-39, Sarayu Residency
Srinagar, Opp. Day and Night
Hospital, Visakhapatnam
A.P. 530016
Mob: +91-9515156438

*Also Operation Office

Download Ozone India App



Visit Website



Android



iOS

Specifications are subject to change without any prior notice



Corporate Office: H-40, Bali Nagar, New Delhi - 110015, INDIA

www.ozone-india.com | Customer Care: +91-9310012300 | customercare@ozone-india.com